

# Acceleration Sensor MM5.10

www.bosch-motorsport.com

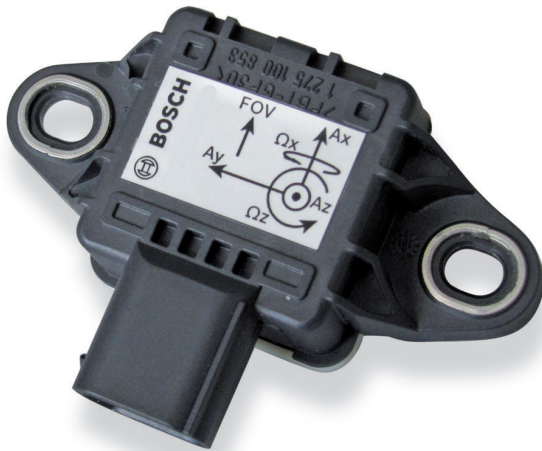

- ▶ 2-axis rotation rate (yaw rate, roll rate)
- ▶ 3-axis accelerometer (X, Y, Z)
- ▶ 1 Mbaud or 500 kbaud CAN-output
- ▶ 15 Hz low-pass filtered
- ▶ Measurement ranges:  $\pm 4.2$  g;  $\pm 163^\circ/\text{s}$

The MM5.10 was designed to measure the physical effects of rotational and linear acceleration. In order to achieve this, the sensor includes MEMS measuring elements connected to an appropriate integrated circuit. A rotational acceleration around the integrated sensing elements generates a Coriolis force which changes the internal capacity of the micro machined sensing parts. Furthermore, a pure surface micro machined element is used to measure the vehicle linear acceleration in all 3 axis. This combination of rotational and lineal acceleration sensors enables a precise measurement of the vehicle dynamics.

The main feature and benefit of this sensor is the combination of 3 linear and 2 rotational accelerometers and its high speed 1 Mbaud/s CAN-signal output.

## Application

Application I	$\pm 163^\circ/\text{s}$ (roll rate/yaw rate)
Application II	$\pm 4.2$ g (X, Y and Z acceleration)
Operating temperature range	-20 to 85°C

## Technical Specifications

### Mechanical Data

Weight w/o wire	35 g
Size	80 x 56 x 21 mm

### Electrical Data

Power supply	7 to 18 V
Max input current	90 mA
CAN speed	1 Mbaud/s or 500 kbaud/s

### CAN Message

#### CAN ID 01 0x174

Byte	Value
0	Yaw rate
1	
2	Reserved
3	
4	Acc Y-axis
5	

6	Reserved
7	Unused
<b>CAN ID 02 0x178</b>	
Byte	Value
0	Roll rate
1	
2	Reserved
3	
4	Acc X-axis
5	
6	Reserved
7	Unused
<b>CAN ID 02 0x17C</b>	
Byte	Value
0	Reserved
1	
2	Reserved
3	
4	Acc Z-axis
5	
6	Reserved
7	Unused
<b>Characteristic</b>	
<b>Characteristic Application I</b>	
Measuring range	± 160°/s
Over range limit	± 1,000°/s
Absolute physical resolution	0.1°/s
Cut-off frequency (-3 dB)	15 Hz; 30 Hz; 60 Hz
<b>Characteristic Application II</b>	
Measuring range	±4.2 g
Over range limit	±10 g
Absolute physical resolution	0.01 g
Cut-off frequency (-3 dB)	15 Hz; 30 Hz; 60 Hz
<b>Connectors and Wires</b>	
Connector (1)	AMP 114-18063-076
Mating connector (1)	F 02U B00 435-01

Pin 1	Gnd
Pin 2	CANL
Pin 3	CANH
Pin 4	UBat
Connector (3)	ASL-6-06-05PC-HE
Mating connector (3)	ASL-0-06-05SC-HE
Pin 1	UBat
Pin 2	Gnd
Pin 3	CANH
Pin 4	CANL
Pin 5	Not connected
Sleeve	DR-25
Wire size	AWG 24
Wire length L	15 to 100 cm

**CAN Parameters**

Byte order	LSB (Intel)
CAN speed	1 Mbaud/s or 500 kbaud/s
Bit mask	unsigned
Offset (all signals)	0x8000 hex
Quantization Yaw Rate	0.005 [°/s/digit]
Quantization Roll Rate	0.005 [°/s/digit]
Quantization Acc X-axis	0.0001274 [g/digit]
Quantization Acc Y-axis	0.0001274 [g/digit]
Quantization Acc Z-axis	0.0001274 [g/digit]

**Installation Notes**

The MM5.10 can be connected directly to most control units and data logging systems.

Please avoid abrupt temperature changes.

For mounting please use only the integrated fixing holes.

Please ensure that the environmental conditions do not exceed the sensor specifications.

Please find further application hints in the offer drawing at our homepage and calibration sheet.

Please deliver the calibration sheet with your order placement.

**Safety Note**

The sensor is not intended to be used for safety related applications without appropriate measures for signal validation in the application system.

**Ordering Information**

**Acceleration Sensor MM5.10**

Without wire (1)

Order number **F 02U V01 511-02**

**Acceleration Sensor MM5.10**

Wire with open end (2)

Order number **F 02U V01 511-91**

**Acceleration Sensor MM5.10**

Wire with motorsport connector (3)

Order number **F 02U V01 512-02**

**Dimensions**

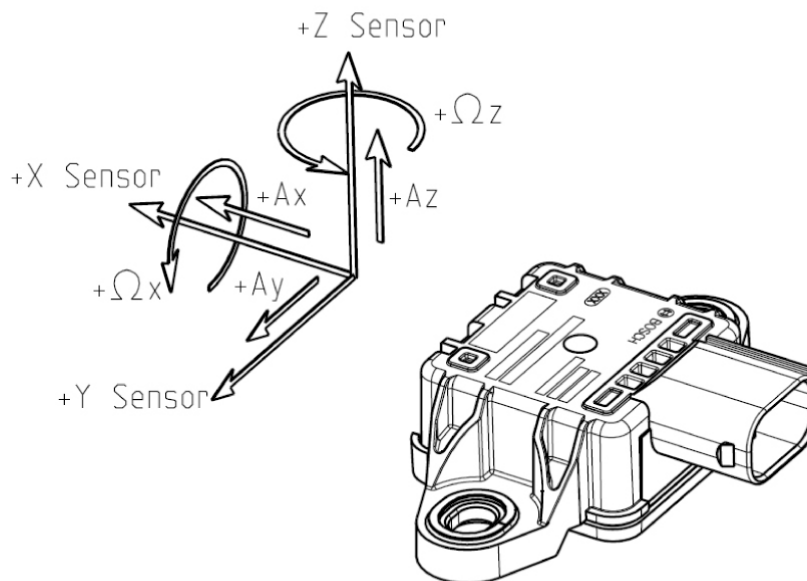
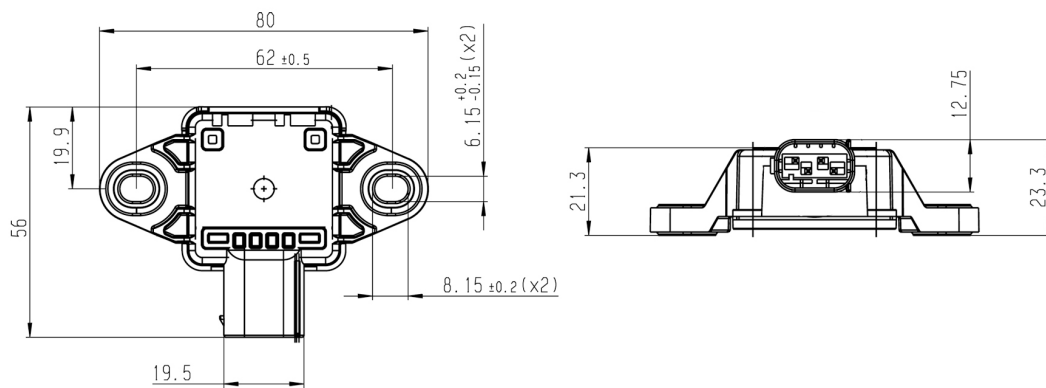

Axis Scheme

**Represented by:**

**Europe:**

Bosch Engineering GmbH  
Motorsport  
Robert-Bosch-Allee 1  
74232 Abstatt  
Germany  
Tel.: +49 7062 911 9101  
Fax: +49 7062 911 79104  
motorsport@bosch.com  
www.bosch-motorsport.de

**North America:**

Bosch Engineering North America  
Motorsport  
38000 Hills Tech Drive  
Farmington Hills, MI 48331-3417  
United States of America  
Tel.: +1 248 876 2977  
Fax: +1 248 876 7373  
motorsport@bosch.com  
www.bosch-motorsport.com

**Latin America:**

Robert Bosch Ltda  
Motorsport  
Av Juscelino Kubitscheck de  
Oliveira 11800  
Zip code 81460-900  
Curitiba - Parana  
Brasilia  
Tel.: +55 41 3341 2057  
Fax: +55 41 3341 2779

**Asia-Pacific:**

Bosch Engineering Japan K.K.  
Motorsport  
18F Queen's Tower C, 2-3-5 Minato Mirai  
Nishi-ku, Yokohama-shi  
Kanagawa 220-6218  
Japan  
Tel.: +81 45 650 5610  
Fax: +81 45 650 5611  
www.bosch-motorsport.jp

**Australia, New Zealand and South Africa:**

Robert Bosch Pty. Ltd  
Motorsport  
1555 Centre Road  
Clayton, Victoria, 3168  
Australia  
Tel.: +61 (3) 9541 3901  
motor.sport@au.bosch.com