

Thermocouple Probe TCP KN 2

www.bosch-motorsport.com

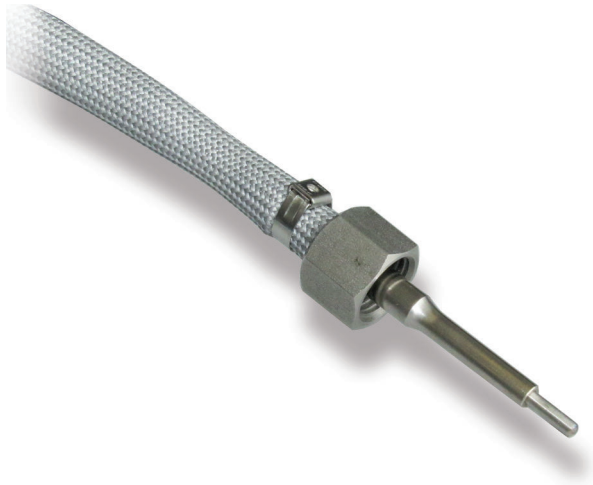

BOSCH
Invented for life



- ▶ Thermocouple Type K
- ▶ Thermo material: NiCr-Ni
- ▶ Measurement range: 0 to 1,250°C
- ▶ Analog output (0 to 5 V) or CAN

This sensor is designed to measure exhaust gas temperatures up to 1,250°C. Thermocouples are temperature sensors that supply a temperature corresponding voltage without any additional external energy source. The thermocouple has a metal mantle that includes two isolated wires made of thermo material NiCr-Ni Type K. The voltage is amplified by an electronic circuit powered by 12 V. Please note that the operating temperature of the external electronics is from 0 to 125°C. The sensing element is protected by a double-walled housing made of Nimonic 75 to enable its placement before turbo chargers. The benefits of this sensor are the combination of high quality production part, robust design and its integrated amplifier

Application

Application	0 to 1,250°C
Operating temp. range (ext. electronics)	0 to 125°C

Technical Specifications

Mechanical Data

Male thread	M14x1.5
Wrench size	17 mm
Installation torque	15 Nm
Weight with wire	85 g

Electrical Data

Voltage supply	12 V
----------------	------

Analog Variant

Full scale output	0 to 5 V
-------------------	----------

T [°C]	U [mV]
0	0
50	197
100	399
200	793
300	1,190
400	1,598

Analog Variant	
500	2,012
600	2,427
700	2,839
800	3,243
900	3,638
1,000	4,022
1,100	4,396
1,200	4,759
1,250	5,000

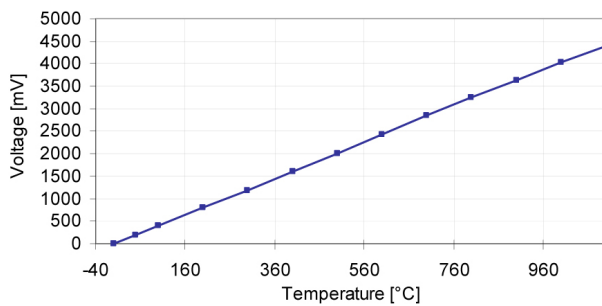

CAN Variant	
CAN Message	
CAN ID 0x3F0 (default)	
Byte	Value
0	Thermocouple Temperature
1	
2	Ambient Temperature
3	
CAN Signals	
Length	16 Bit
Byte order	Motorola (Big Endian)
Bit mask	Signed
Factor	0.1°C/Bit
Offset	0.0
CAN Parameter	
CAN speed	1 Mbaud/s or 500 kbaud/s (default 1 Mbaud)
CAN frequency	100 Hz Thermocouple Temp. 1 Hz Ambient Temp.

CAN Variant	
Phys. unit	Degrees Celsius (default) or Degrees Fahrenheit
CAN Frame ID	0x1 to 0x7F0 (default 0x3F0)
Please specify the requested CAN parameters with your order in the calibration sheet.	

Connectors and Wires	
Sleeve	DR-25
Wire size	AWG 24
Wire length L	15 to 75 cm

Analog Variant	
Connector	ASU 6-03-03PD-HE
Mating connector	ASU 0-03-03SD-HE
Pin 1	Power supply 5 to 16 V
Pin 2	Gnd
Pin 3	Signal 0 to 5 V

CAN Variant	
Connector	ASU 6-03-05PB-HE
Mating connector	F 02U 000 207-01 ASU 0-03-05SB-HE
Pin 1	U _s
Pin 2	Gnd
Pin 3	CAN High
Pin 4	CAN Low
Pin 5	Not connected

Installation Notes

The TCP KN2 can be connected to Bosch Motorsport ECUs with a 0 to 5 V analog signal input (w/o pull-up resistor) or to external data logging devices.

The sensor can be mounted individually according to the customer's request.

Please note that the operating temperature range of the external electronics is from 0 to 125°C.

Recommended bending radius of the wire of the sensor element is minimum 20 mm to ensure the sensor works properly and for a longer life-span of the sensor.

Any mounting orientation is possible.

Please find further application hints in the offer drawing and free download of the sensor configuration file (*.sdf) for Bosch Data Logging System at our homepage.

Safety Note

The sensor is not intended to be used for safety related applications without appropriate measures for signal validation in the application system.

Ordering Information

Thermocouple Probe TCP KN 2

Analog Variant

Order number **F 02U V01 863-01**

Thermocouple Probe TCP KN 2

CAN Variant

Order number **F 02U V02 425-01**

Dimensions

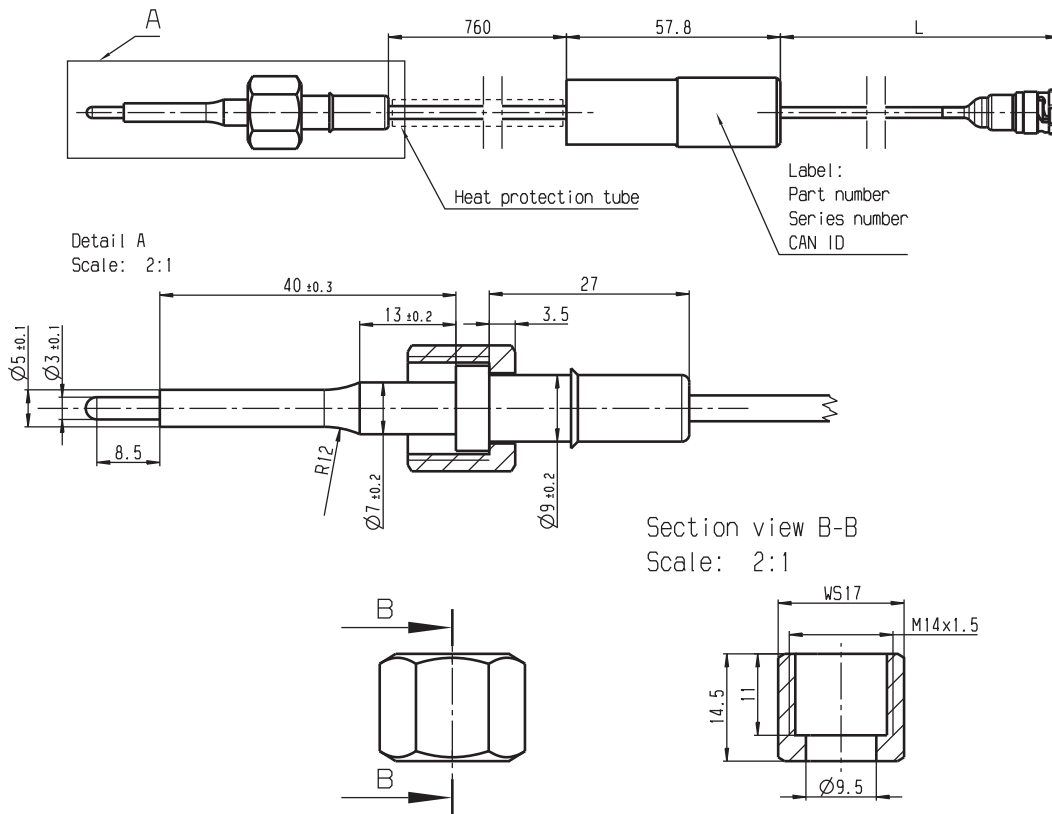

CAN Variant (Analog Variant: see website)

Represented by:

Europe:
 Bosch Engineering GmbH
 Motorsport
 Robert-Bosch-Allee 1
 74232 Abstatt
 Germany
 Tel.: +49 7062 911 9101
 Fax: +49 7062 911 79104
 motorsport@bosch.com
 www.bosch-motorsport.de

North America:
 Bosch Engineering North America
 Motorsport
 38000 Hills Tech Drive
 Farmington Hills, MI 48331-3417
 United States of America
 Tel.: +1 248 876 2977
 Fax: +1 248 876 7373
 motorsport@bosch.com
 www.bosch-motorsport.com

Latin America:
 Robert Bosch Ltda
 Motorsport
 Av Juscelino Kubitschek de
 Oliveira 11800
 Zip code 81460-900
 Curitiba - Parana
 Brasilia
 Tel.: +55 41 3341 2057
 Fax: +55 41 3341 2779

Asia-Pacific:
 Bosch Engineering Japan K.K.
 Motorsport
 18F Queen's Tower C, 2-3-5 Minato Mirai
 Nishi-ku, Yokohama-shi
 Kanagawa 220-6218
 Japan
 Tel.: +81 45 650 5610
 Fax: +81 45 650 5611
 www.bosch-motorsport.jp

Australia, New Zealand and South Africa:
 Robert Bosch Pty. Ltd
 Motorsport
 1555 Centre Road
 Clayton, Victoria, 3168
 Australia
 Tel.: +61 (3) 9541 3901
 motor.sport@au.bosch.com